



BAUMALIGHT™

Trencher

OPERATOR'S MANUAL

**THE RIGHT
EQUIPMENT**

Issue Date: December 2014

TABLE OF CONTENTS

SECTION	DESCRIPTION	PAGE
1	Introduction	1
1.1	Overview	1
1.2	Intended Use and Foreseeable Misuse	2
2	Safety	3
2.1	Safety Alert Symbol and Safety Words	3
2.2	Operational Hazards	4
2.3	Maintenance Hazards	8
3	Safety Signs	10
4	Initial Setup	12
4.1	Remove Trencher From Pallet	12
4.2	Hydraulics	13
5	Operation	14
5.1	Preparation For Use	14
5.2	Pre-Operation Check List	14
5.3	Machine Components	15
5.4	Attaching Trencher To Power Unit	16
5.5	Detaching Trencher From Power Unit	16
5.6	Transporting	17
5.7	First Time User Tips	17
5.8	Field Operation	18
6	Service and Maintenance	20
6.1	Maintenance	20
6.2	Inspections	21
6.3	Replace Cutting Teeth	21
6.4	Lubricate Idler Bearing	22
6.5	Check Chain Tension	22
7	Troubleshooting	23
8	Storage	24
8.1	Storing Trencher	24
8.2	Removing Trencher from Storage	24
9	Warranty	25

1 INTRODUCTION

1.1 Overview

Congratulations on your choice of a Baumalight Trencher to complement your trenching operation. This equipment has been designed and manufactured to meet the needs of a discriminating buyer for efficient trenching.

The trencher is hydraulic powered by the hydraulic system on your power unit.

Replaceable bearings are provided at major pivot points for extended service life.

Safe, efficient and trouble free operation of your trencher requires that you and anyone else who will be operating or maintaining the trencher, read and understand the Safety, Operation, Maintenance and Troubleshooting information contained within the Operator's Manual.

This manual covers Baumalight Trenchers. Use the Table of Contents as a guide to locate required information.

Keep this manual for frequent reference and to pass on to new operators or owners. Call your Baumalight dealer, distributor or the factory if you need assistance, information or additional copies of the manuals.

When this machine is worn out and no longer in use, it should be returned to the retailer or other party for recycling.

OPERATOR ORIENTATION - The directions left, right, front and rear, as mentioned throughout this manual, are as seen from the driver's seat and facing in the direction of travel.

1.2 Intended Use and Foreseeable Misuse

The trencher is designed to be used by experienced operators, trained in the safe operation of the power unit and trained in the hazards related to using the trencher and the safe use of the trencher for the intended purpose. Operators will require personal protective equipment to reduce the risk from some hazards that cannot be completely eliminated or controlled by the design of the tool.

Care is required to ensure that the trencher will not come across metallic objects, stones or other materials.

Trenchers are not designed for use in hazardous atmospheres where there is a risk of fire or explosion due to flammable gases or vapours. Use in hazardous, explosive atmospheres is prohibited.

Serious injury or death of the operator or bystanders may be caused if the tool is misused. Misuse may also cause damage to the machine carrying the implement.

2 SAFETY

2.1 Safety Alert Symbol and Safety Words

You must read, understand and follow the instructions given by the operating unit manufacturers, as well as the instructions in this manual.

The safety information in this manual is denoted by the safety alert symbol:



This symbol means ATTENTION! BECOME ALERT! YOUR SAFETY IS INVOLVED!

The level of risk is indicated by the following signal words:

DANGER

DANGER - Indicates a hazardous situation, which, if not avoided, **WILL** result in death or serious injury.

WARNING

WARNING - Indicates a hazardous situation, which, if not avoided, could result in death or serious injury.

CAUTION

CAUTION - Indicates a hazardous situation, which, if not avoided, could result in minor or moderate injury.

NOTICE

NOTICE - Indicates a situation that could result in damage to the equipment or other property.

2.2 Operational Hazards

WARNING

Prevent serious injury or death.

Read and understand this manual before operating trencher.

Always stop engine and remove key before leaving operators seat.

Never allow anyone near the trencher during operation.

Travel at a safe speed.

WARNING

Use trencher only for the designed applications.

Any other use may result in personal injury, damage to equipment and may void the warranty.

WARNING

Prevent serious injury or death.

Verify trencher is attached to power unit before operation or transport.

WARNING

Prevent serious injury or death from moving parts.

Moving parts can crush and dismember.

Do not operate without guards and shields in place.

Disconnect and lock out power source before adjusting or servicing.

WARNING

Protect from flying debris.

Wear proper safety glasses, goggles, or a face shield to protect from flying debris.

Carefully read all safety messages in this manual and on equipment safety signs. Keep safety signs in good condition and replace missing or damaged safety signs.

New equipment components and repair parts must include the current safety decal.

Learn how to properly operate equipment. NEVER operate or work around this equipment without proper instruction, while fatigued or under the influence of alcohol, prescription or non-prescription medication or if feeling ill.

Keep your equipment in proper working condition.

Know the regulations and laws that apply to you and your industry. This manual is not to replace any regulations or laws. Additional information may be found at: www.asae.org or www.osha.gov.

If you do not understand any part of this manual, contact Baumalight at 866-820-5603.

Prepare for Emergencies

- Be prepared in case of emergencies.
- Keep a fire extinguisher and first aid kit close to the machine.
- Know emergency phone numbers for your area.
- Know your address so emergency services can locate you if an emergency arises.

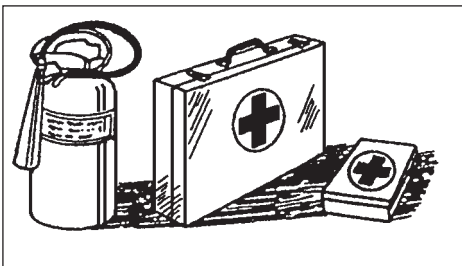

Replace Safety Signs

- Replace missing or damaged safety signs.
- Safety signs are identified in Section 3 of this manual.
- Replacement safety signs are available from your Baumalight dealer.

Do Not Allow Riders

- NEVER lift or carry anyone with trencher.
- NEVER use trencher as a work platform.
- NEVER allow passengers on trencher.

Lower Operating Speed

- Keep load low and move at slow speeds on rough or uneven terrain.

Avoid Rollover

The equipment may rollover, resulting in death or serious injury. To help prevent rollover:

- Travel at a slow speed.
- Avoid sharp turns & sudden movement on slopes.
- Carry load close to the ground.

- Avoid holes, ditches and other obstructions which may cause equipment to rollover.
- Balance load so weight is evenly distributed and load is stable.
- Use caution when operating on slopes and do not operate on excessively steep slopes.
- Do not exceed load capacity of equipment.

Avoid Powerlines & Underground Utilities

DANGER

Prevent electrocution.

Death or serious injury can result if equipment comes near or contacts power lines.

Electrocution can occur without direct contact.

DO NOT leave the operator's seat if any part of the equipment contacts electric lines or cables.

Detach Trencher Safely

Detach trencher on a firm and level surface. Be sure people, livestock and pets are clear of machinery.

Relieve hydraulic pressure before disconnecting hydraulic hoses. See your power unit Operator's Manual.

Raised Attachment

WARNING

Crushing hazard.

Raised, unsupported trencher can fall, resulting in death or serious injury.

Never enter the area under a raised trencher.

A raised trencher can lower unexpectedly, resulting in death or serious injury.

NEVER enter area under a raised trencher.

Lower trencher to ground, engage parking brake, shut off engine and remove key before servicing.

Avoid Loud Noise

⚠ WARNING

Prolonged exposure to loud noise can cause impairment or loss of hearing.

Wear a suitable hearing protective device to protect against objectionable or uncomfortable loud noises.

Hazards From Modifying Equipment

Do not make any alterations to your trencher. Altering the equipment may cause unsafe conditions and may void the manufacturer's warranty.

Avoid High Pressure Fluids

⚠ WARNING

Pressurized fluids can penetrate the skin.

Hydraulic hoses can fail from age, damage and exposure.

Use body and face protection while searching for leaks. A tiny, almost invisible leak can penetrate the skin, thereby requiring immediate medical attention.

Use wood or cardboard to detect hydraulic leaks, never use your hands.

Escaping fluid under pressure can penetrate the skin causing serious injury.

Prevent the hazard by relieving pressure (See power unit Operator's Manual) before connecting or disconnecting hydraulic lines. Verify all connections are tight before applying pressure.

Search for leaks with a piece of cardboard or wood.

Protect hands and body from high pressure fluids. If an accident occurs, see a doctor immediately. Any fluid injected into the skin must be surgically removed within a few hours or serious infection may result.

2.3 Maintenance Hazards

Before servicing, park machine on a firm and level surface, set parking brake, chock wheels, and place a “Do Not Operate” tag on control panel. Read and understand this manual. If you do not understand any part of the manual, contact Baumalight at 866-820-5603.

Always wear face and/or eye protection, safety shoes, and other protective equipment appropriate for the job.

Do not make unauthorized modifications. Contact Baumalight at 866-820-5603 before you weld, cut/drill holes, or make any other modifications.

Always use Baumalight replacement parts.

WARNING

Moving parts can crush and cut.

Keep clear of moving components.

Follow lockout procedure before servicing.

WARNING

Crushing hazard.

Before performing inspections, service or maintenance:

Park machine on firm, level surface.

Engage parking brake.

Turn engine off and remove key.

Place “Do Not Operate” tag on control panel.

WARNING

Entanglement hazard.

Keep clear of moving components.

Wear proper protective equipment appropriate for the job.

WARNING

Burn hazard.

Hot and high pressure hydraulic oil.

Allow oil to cool before servicing.

This page intentionally left blank.

3 SAFETY SIGNS

NS - Non-Slip Pad

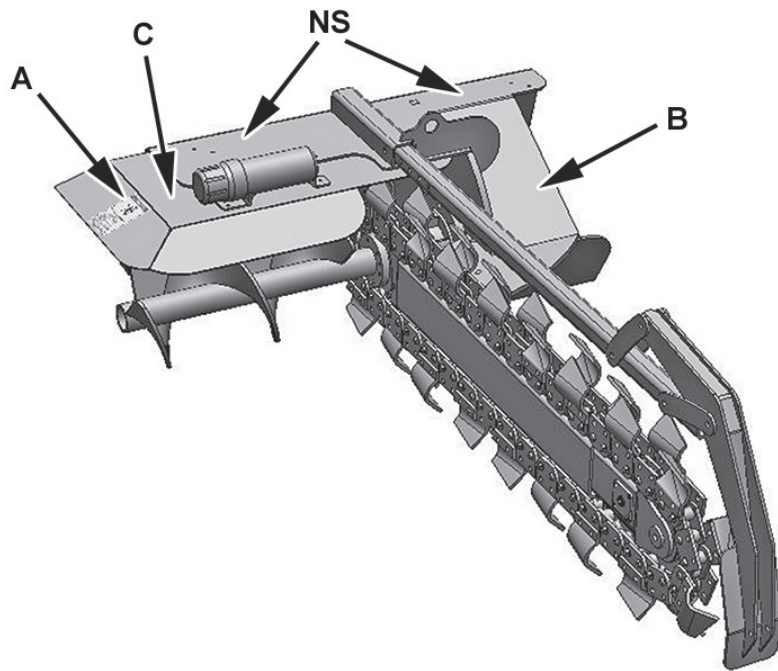



A. MTB-185 Safety Sign



B. MTB-182 Safety Sign

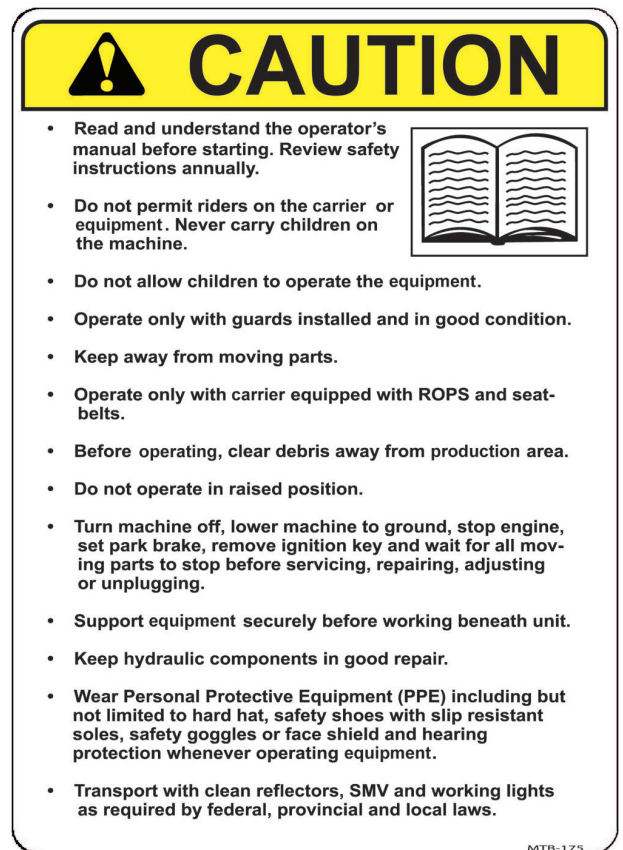

C. MTB-175 Safety Sign

4 INITIAL SETUP

4.1 Remove Trencher From Pallet

⚠ WARNING

The trencher weighs approximately 1175 lbs.

Trencher is top heavy when attached to pallet. Move with caution.

Do not position feet under pallet or trencher.

1. Attach an adequate lifting device to hole (A) in scraper bar frame. Take up slack so lifting device is tight.
2. Remove all shipping bands. Raise trencher slightly and remove pallet from work area.
3. Lower trencher until chain touches the ground.
4. Remove lifting device.

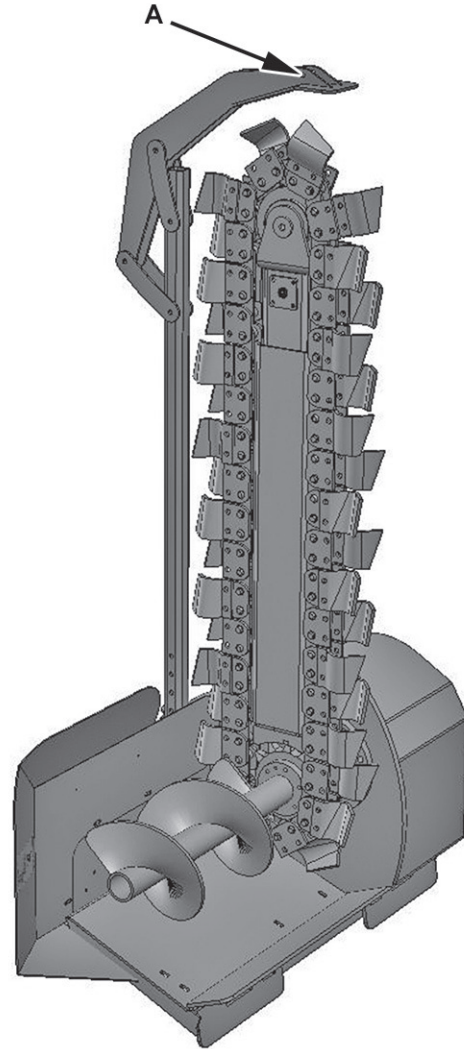

4.2 Hydraulics

WARNING

Pressurized fluids can penetrate the skin.

Disconnect and lock out power source before disconnecting and/or connecting hydraulic hoses.

The trencher is equipped with hoses that are connected to the hydraulic motor. You must connect your power unit hoses to these hoses.

Power unit hoses must be the same size as the trencher hoses. Using smaller diameter hoses will decrease hydraulic flow.

5 OPERATION

5.1 Preparation for Use

Although the trencher has been carefully inspected and checked prior to shipment from manufacturer, it is recommended that the unit be thoroughly inspected.

Check all bolts for tightness and remove all shipping tags, bags, skids, and blocking.

Review and understand this manual and operating unit manual.

Remove any masking materials affixed during painting. Inspect the trencher and any accessory equipment to verify that nameplates and all safety warning, caution signs and decals provided with the equipment are in place and clearly visible.

Visually inspect the unit before each start up.

Check for loose or missing parts and any damage that may have occurred during moving or shipping.

Review all power unit pre-start instructions, and be sure that all recommended steps and procedures have been followed.

NOTE: Always keep the weight of the machine in mind. Never position body in line of impact.

5.2 Pre-Operation Check List

Check-mark	Check these items:	Frequency
	Verify that trencher is properly attached to power unit.	Each operation.
	Verify that hydraulic hoses are connected to power unit hydraulic couplers.	Each operation.
	Check for entangled material on chain.	Each operation.
	Verify all guards, doors and covers are installed and secured.	Each operation.
	Verify cutting teeth on the chain are tight.	Every 4 hours.

5.3 Machine Components

- A. Side Auger
- B. Operators Manual Storage Tube
- C. Quick Attach
- D. Hydraulic Motor
- E. Cutting Tooth
- F. Scraper Bar
- G. Optional 3-Point Adapter
- H. Angle/Depth Control Cylinder

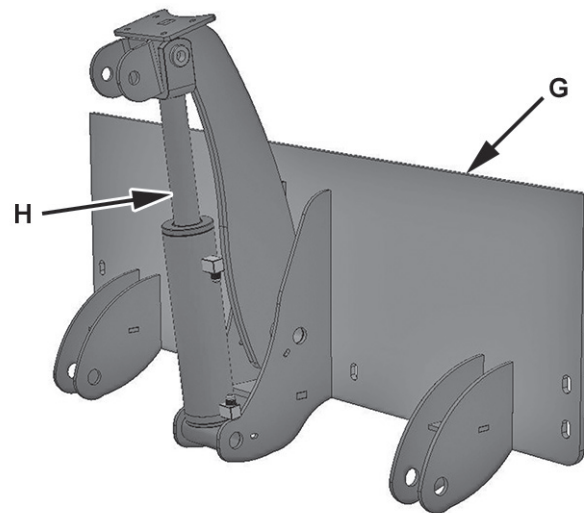
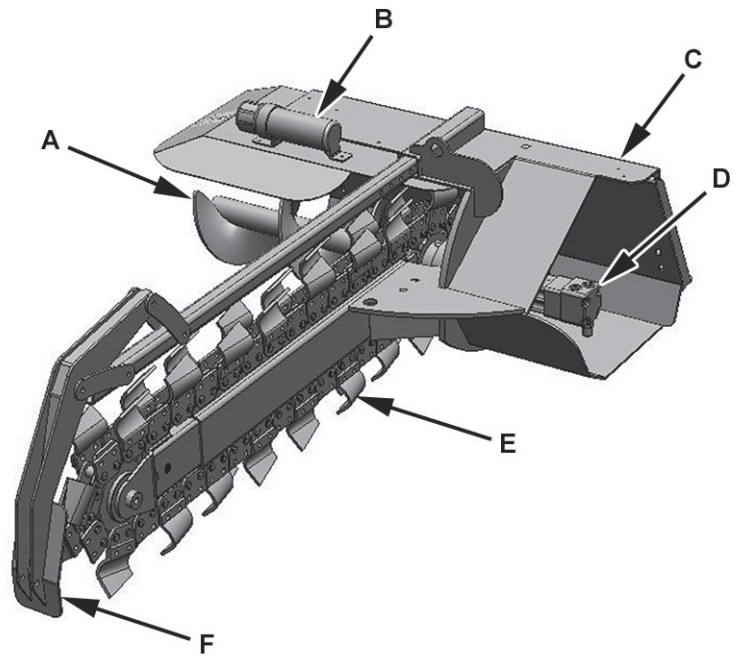

5.4 Attach Trencher To Power Unit

⚠ WARNING

To prevent injury or machine damage put transmission in “Park”.

Never position yourself between power unit and trencher.

Only experienced and properly trained operator’s should operate the power unit and trencher.

1. Read and follow all safety instructions.
2. Attach trencher to power unit. See power unit Operator’s Manual.
3. Verify pins are secure in the correct position.
4. Connect hydraulic hoses. Verify hydraulic hoses are clear of pinch areas and moving parts.
5. Move to a clear open area to test functions.

5.5 Detach Trencher From Power Unit

⚠ WARNING

Prevent serious injury or death caused by unexpected movement:

1. Park on a level surface.
2. Engage park brake.
3. Disconnect hydraulic drive.
4. Shut off engine and remove key.

1. Park power unit on a level surface.
2. Lower trencher to the ground.
3. Shut off engine and remove key.
4. Disconnect hydraulic hoses.
5. Detach trencher from power unit. See power unit Operator’s Manual.

5.6 Transporting

1. Verify all reflectors and Slow Moving Vehicle (SMV) sign are visible.
2. Raise trencher slightly off ground.
3. Verify hydraulics are disengaged.
4. Travel at a reasonable and safe speed.

WARNING

To prevent bodily injury from rotating cutting wheel, be sure to disengage hydraulics before transporting trencher.

5.7 First Time User Tips

DANGER

Prevent electrocution.

Death or serious injury can result if equipment comes near or contacts power lines.

Electrocution can occur without direct contact.

- First, operate all functions in a clear area with power unit at idle speed to get a good feel for the controls before you actually dig a trench.
- Run throttle only at half speed for first time users.
- Lower trencher slowly until you have a better feel how much the unit can take.
- If the chain stops turning, move power unit back a few inches until chain starts to turn again. Avoid raising out of trench if you don't have to, because you will have to measure your trench again to ensure you are digging the same depth along the trench.

WARNING

Always turn off the power unit and disengage hydraulic drive before getting off the seat and approaching the chain.

5.8 Field Operation

DANGER

Prevent electrocution.

Death or serious injury can result if equipment comes near or contacts power lines.

Electrocution can occur without direct contact.

WARNING

Prevent serious injury or death caused by unexpected movement:

- 1. Park on a level surface.**
- 2. Engage parking brake.**
- 3. Disengage hydraulic drive.**
- 4. Shut off engine and remove key.**

WARNING

Never operate trencher when other people are in the vicinity.

Do not allow riders.

1. Attach trencher to power unit. See Attach Trencher To Power Unit in this section.
 2. Place unit so that the chain is a couple of inches above the ground, and so chain is slightly tilted up.
 3. Start hydraulic oil flow to start chain rotation. After chain is rotating slowly, lower trencher into the ground.
 4. Slowly increase engine speed to high idle.
 5. Start tilting chain down at a steady slow pace until at desired depth. Verify trencher is operating smoothly and start travel.
- If the chain stops turning, move power unit back a few inches until chain starts to turn again. Avoid raising out of trench if you don't have to, because you will have to measure your trench again to ensure you are digging the same depth along the trench.
 - It is recommended that you measure the trench several times at the beginning of the digging process to ensure that the desired depth is dug.
 - When raising out of the trench, always keep the chain rotating until completely raised above ground, if chain is not rotating it could catch a stone or a solid object as you are raising the out of the ground.

⚠ WARNING

Moving parts can crush and cut.

Keep clear of moving components.

Lockout operating unit before clearing jams.

⚠ WARNING

Always turn off the power unit and disengage hydraulic drive before getting off the seat and approaching the chain.

6 SERVICE and MAINTENANCE

6.1 Maintenance

Maintenance Chart		
General Inspection	Inspect the unit for any buildup of contamination (dirt, stones, etc.).	Daily
Cutting Teeth	Check and replace one at a time as necessary. See Replace Cutting Teeth in this section.	Daily.
Idler Bearing	Grease idler bearing. Do not over grease bearing. Grease escaping around seal will collect dirt and cause premature bearing failure.	Every 4 Hours.
Chain Tension	Check chain tension. Chain should be taught.	Daily.

6.2 Inspections

⚠ WARNING

Prevent serious injury or death caused by unexpected movement:

1. Park on a level surface.
2. Engage parking brake.
3. Disengage hydraulic drive.
4. Shut off engine and remove key.

Inspect the unit for any buildup of contamination (dirt, stones, etc.).

Check cutting teeth daily. Keep cutting teeth in good condition. Unit will cut faster and remaining teeth will last longer if broken teeth are replaced.

6.3 Replace Cutting Teeth

1. Park trencher on a level surface.
2. Lower trencher to the ground.
3. Shut off engine and remove key.
4. Inspect cutting teeth (A) for damage and wear. Replace individual teeth as needed.
5. Remove bolts, locknuts and tooth (A). Install new tooth.
6. Install and tighten bolts and locknuts.

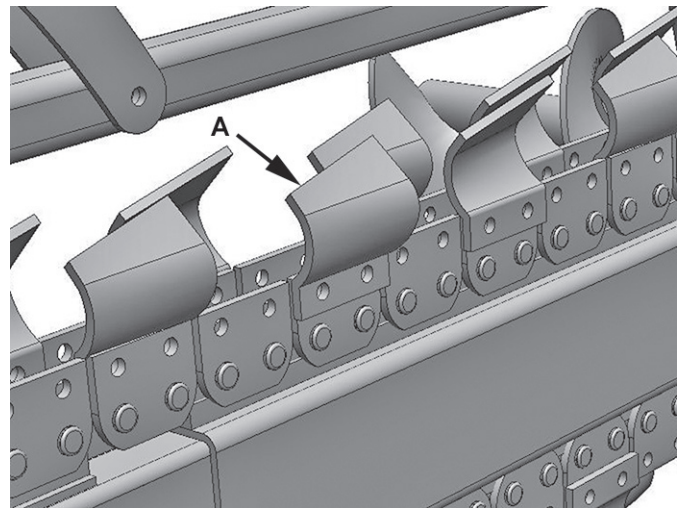

Note: Parts breakdown can be found on BaumaLight's website. www.baumalight.com

6.4 Lubricate Idler Bearing

1. Park trencher on a level surface.
2. Lower trencher to the ground.
3. Shut off engine and remove key.

NOTICE

Do not over grease idler. Grease escaping around seal will collect dirt and cause premature bearing failure.

4. Pump grease into fitting (A) on idler.

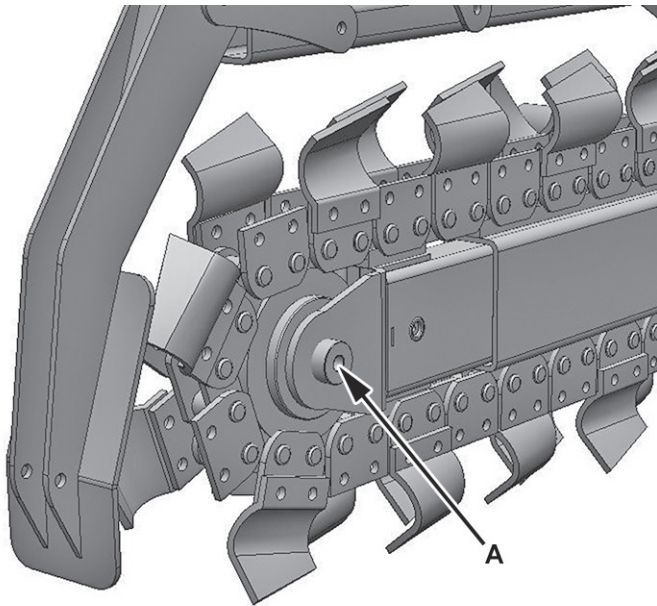

6.5 Check Chain Tension

1. Park trencher on a level surface.
2. Lower so trencher is slightly above the ground.
3. Shut off engine and remove key.
4. Check chain tension. You should be able to lift chain 1.5 inches off top of track.
5. Pump grease into fitting (B) to tension chain.

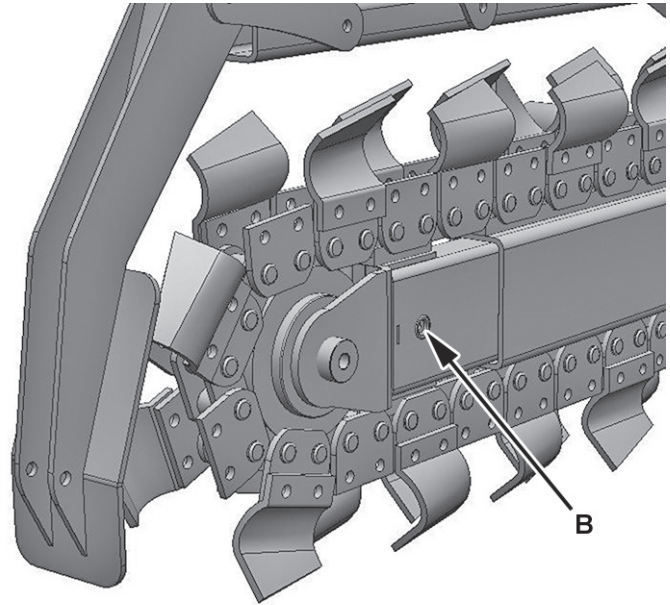

7 TROUBLESHOOTING

PROBLEM	CHECK	SOLUTION
Chain does not rotate.	Chain jammed.	Remove material from chain.
	Chain off track.	Place chain back on track.
	Low oil level.	Check oil level in power unit. Add if necessary.
	Low oil flow.	Check flow control on power unit. See your dealer.
Chain rotates slow or sluggish.	Low oil.	Check oil level in power unit. Add if necessary.
	Oil filter plugged.	Replace oil filter.
	Relief valve not set properly.	Set relief pressure to motor specification.
	Low oil flow.	Check flow control on power unit. See your dealer.
Excessive vibration.	Chain too loose.	Tighten chain.
	Cutting teeth worn or missing.	Replace worn, broken or missing teeth.
	Debris lodged in chain.	Remove debris.

8 STORAGE

8.1 Storing Trencher (End Of Season)

1. Store trencher in a dry place.
2. Clean trencher thoroughly. Dirt will draw moisture and cause rust.
3. Check condition of cutting teeth. Replace as necessary. (See Service and Maintenance section.)
4. Check for loose or missing hardware.
5. Paint parts as necessary.

8.2 Removing Trencher From Storage (Beginning Of Season)

1. Review Operator's manual and check adjustments.
2. If parts have been replaced, verify they run properly.

9 WARRANTY

This product is warranted to be free of defects in materials and workmanship under normal use and service, for a period of one year from the date of purchase, when operated and maintained in accordance with the Operating and Maintenance Instructions supplied with this unit. This warranty does not cover misuse or negligence.

Under no circumstances will the manufacturer be liable for any consequential damage or expense of any kind, including loss of profits. The manufacturer is under no circumstances liable for power unit damage of any kind. The manufacturer is not liable for the maintenance of the product.

This warranty is extended only to the original purchaser. Warranty is void if repairs are attempted by anyone other than an Authorized Service Center.

If a difficulty develops with the product, you should contact your nearest Authorized Repair Center, or distributor. Only these locations are authorized to make repairs to the product or affect the replacement of defective parts, which will be done at no charge within a reasonable time after the receipt of the product. Units or parts should be returned at the customer's expense to the nearest repair location or Authorized Service Center. Pack unit in a strong carton and pad tightly to avoid damage. Damage in-transit is not covered by warranty. Include original purchase receipt with any claim (keeping a copy for your files).

The Manufacturer's Liability is limited to repair of the product and/or replacement of parts and is given to the purchaser in lieu of all other remedies including incidental and consequential charges. There are no warranties, expressed or implied other than those specified herein. For the nearest Authorized Service Center call the manufacturer.

Please note the following details and file this information in an appropriate place.

Model Number: _____ S/N: _____

Date of Purchase: _____ Owner's Name _____

MTB MFG INC.
CORPORATE HEADQUARTERS
4575 Powell Rd.,
Wallenstein, Ontario Canada
N0B 2S0
Phone - 519.698.9864
Toll Free - 866.820.5603
Fax - 519.698.1087
www.baumalight.com

